

**EXPRESS SETUP**

# PanelMate 5000 Series

## Models

5000 Touchscreen

5000 TouchPanel

5000 Split



*Powered by* 

# Hardware Installation

## Unpacking

Carefully remove all equipment from the packing cartons and inspect all parts for damage in shipment. Check packing cartons for all items shown on the packing list. Keep the cartons and packing materials for future shipment.

If there is equipment damage due to shipment, report the damage to the carrier who delivered the equipment.

**Note:** The Interstate Commerce Commission has a time limit on reporting concealed damage.

## 5000 Touchscreen and TouchPanel Parts Checklist

Your packing carton contains one parts kit containing:

- 1 packet of mounting nuts and washers
- 2 two-terminal connectors (audio output and security keyswitch)
- 1 three-terminal connector (24VDC power)
- 1 four-terminal connector (fault relay)

## 5000 Split Parts Checklist

Your packing carton contains one parts kit containing:

- 1 packet of mounting nuts and washers
- 2 two-terminal connectors (audio output and security keyswitch)
- 1 three-terminal connector (24VDC power)
- 1 four-terminal connector (fault relay)
- Cable mounting clamp, screw and washers

## Safety Considerations

This equipment is suitable for Class I, Division 2, Groups A,B,C,D or non-hazardous locations only.



### CAUTION

---

EXPLOSION HAZARD. SUBSTITUTION OF COMPONENTS MAY IMPAIR SUITABILITY FOR CLASS I, DIVISION 2.

---



### ADVERTISSMENT

---

RISQUE D'EXPLOSION. LA SUBSTITUTION DE COMPOSANTS PEUT RENDRE CE MATERIEL INACCEPTABLE POUR LES EMPLACEMENTS DE CLASSE I, DIVISION 2.

---

## Mounting

Your PanelMate 5000 unit is approved for use in Type 4, 4X and 12 installations when properly mounted in a correspondingly rated enclosure.

Proper installation and enclosure sizing is essential to ensure long life and trouble-free operation. Your PanelMate 5000 unit should always be mounted in a vertical position. Flat or angled mounting positions will severely shorten the unit's life.

Panel cutout dimensions and stud torque limits are shown on the Cutout Templates in this document.

**Note:** Stud nuts must be tightened enough to obtain a proper seal, but not over-tightened to the point where the threads are stripped or the gasket is rendered useless. Always use a torque wrench when installing your PanelMate 5000 unit.



### WARNING

---

EXPLOSION HAZARD. DO NOT REPLACE COMPONENTS UNLESS POWER HAS BEEN SWITCHED OFF OR AREA IS KNOWN TO BE NON-HAZARDOUS.

---



### ADVERTISSMENT

---

RISQUE D'EXPLOSION. COUPER LE COURANT OU S'ASSURER QUE L'EMPLACEMENT ES DESIGNE NON DANGEREUX AVANT DE REPLACER LE COMPOSANTS.

---

# Connections

## Connect DC Power

Your PanelMate 5000 unit is designed to operate at 24VDC -15%/+20%. A removable three-position DC power connector attaches to the unit's connector receptacle. The DC input common (-terminal) and the chassis GND terminal are both internally connected to the PanelMate 5000 chassis.

**Note:** Use #18 AWG (0.82mm<sup>2</sup>) copper wire for power and ground lead connections.

**Note:** Power conditioning may be required when the PanelMate 5000 unit is installed in areas of poor power quality.

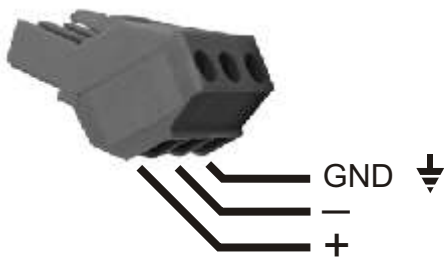

## CAUTION

Your PanelMate unit could be severely damaged if it is connected to voltages outside the range of 18 to 30VDC. Your PanelMate unit is fully protected against polarity reversal and will not operate if input polarity is reversed.

## Connection to a Personal Computer

Executive firmware and PanelMate configurations are uploaded/downloaded to a personal computer using the PanelMate unit's Serial Port 1. A transfer serial cable is provided with your PanelMate Configuration software. Refer to your PanelMate Getting Started Manual for more information.

## Connection to the Fault Relay

The fault relay may be wired in normally open or normally closed configuration. It is a Form C contact, rated for 2 amps at 120VAC, 2 amps at 230VAC, and 2 amps at 28VDC resistive load. During normal operation, the fault relay will energize after entering Run Mode. Whenever the PanelMate unit detects a communication error or system failure, the fault relay will be de-energized. It is also possible to de-energize the fault relay whenever an alarm condition occurs. You can set the fault relay to de-energize on alarms by using the System Parameters Table. Refer to the System Parameters topic in the Configuration Software Online Help and in the Configuration Editor User's Guide for more information.

## Connection to the Audio Output

The Audio Feedback Kit is an optional accessory to your PanelMate unit. To connect the external 8 Ohm speaker to your PanelMate unit, connect the speaker to the Audio connector.

## Connection to the Security Keyswitch

The Security Keyswitch connection is provided for external security/password applications.

## Split Models - TouchPanel Connection to the Display Module

For easier installation, your PanelMate unit is shipped with the TouchPanel disconnected from the display module. Connect and secure the TouchPanel cable as illustrated, using the clamp, star washer, flat washer and screw included in the parts list.

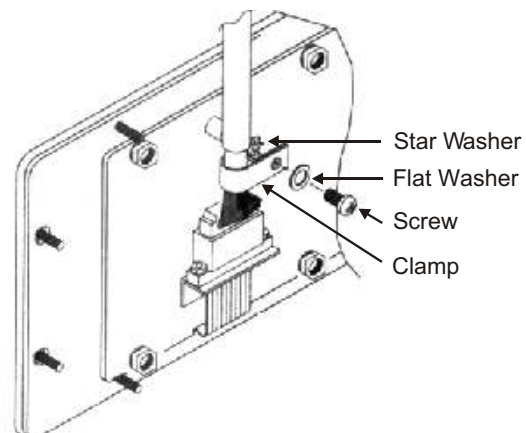

# Connections, Continued

## Connecting to Serial Ports

Serial Port 1 may be used for a printer, for PLC (or Host) communications, or for connection to a personal computer for upload or download. Serial Port 2 may be used for printer or for PLC (or Host) communications.

Selection of Port 1 for a serial printer must be done with the Configuration Software. Refer to the PLC Name and Port Table topic in the Configuration Software Online Help and in the PanelMate Configuration Editor User's Guide for more information.

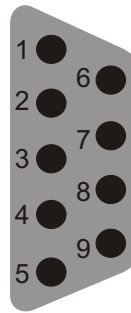

Pin	Description
1	RS422 Transmit Data (+) (Output)
2	RS232 Receive Data (Input)
3	RS232 Transmit Data (Output)
4	RS422 Receive Data (+) (Input)
5	Signal Ground
6	RS422 Transmit Data (-) (Output)
7	RS232 Request to Send (Output)
8	RS232 Clear to Send (Input)
9	RS422 Receive Data (-)

## Serial Port Termination

Your PanelMate unit is sent without termination. For Serial Port termination switch locations, refer to Figure A. Recommended termination for RS232, DH485 and RS422 communication is shown in the table. For setting the termination on Serial Port 1, use the termination switch on the left of Serial Port 1. For setting the termination on Serial Port 2, use the termination switch on the right of Serial Port 2.

Communication	Position	Termination
RS232	1	None (Factory Setting)
DH485	4	120 Ohm AC coupled
RS422/RS485	2 & 3	Refer to your PLC Communications Driver Manual for termination information

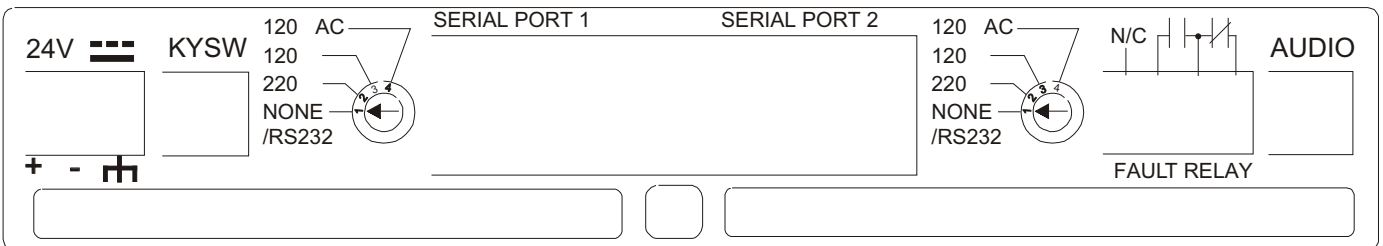

Figure A



## CAUTION

Your PanelMate unit is equipped with isolated Serial Ports for improved communications reliability. If you are replacing a 120VAC Power Series unit or a Power Series 1500 unit, and are using an RS422 or RS485 cable for PLC communications, you may need to install a new cable equipped with a ground wire. Consult your PLC communications driver manual or contact Cutler-Hammer Technical Support for more information.

# Tests and Adjustments

## PanelMate Diagnostic Tests

When power is applied to your PanelMate unit, the unit will display a listing of internal diagnostic checks as they are executed. After completing its internal diagnostic checks, the unit will display the Offline Mode Menu.

The **PanelMate TouchPanel and Split** menu displays the five selections shown below:



The **PanelMate Touchscreen** menu displays the six selections shown below:

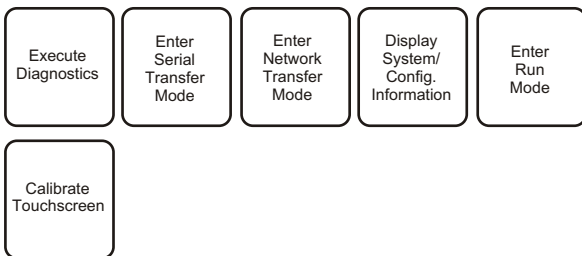

## Execute Diagnostics

This template allows you to perform a series of tests:

- Set Date and Time
- Display test
- Touchscreen test
- Tone, relay and battery test
- System status

For information on performing these tests, refer to your PanelMate Getting Started Manual.

## Enter Serial Transfer Mode

To download, upload or read system information over Serial Port 1, your PanelMate unit must be in Serial Transfer Mode. For more information on downloading and uploading PanelMate configurations, refer to your PanelMate Getting Started Manual.

## Enter Network Transfer Mode

Network transfer mode is used to read system information over a remote network or remotely place your PanelMate unit into Run Mode. For more information, refer to your PanelMate Transfer Utility User's Manual.

## Display System Configuration Information

This selection displays your PanelMate unit's current configuration. Your PanelMate unit is shipped with a demonstration PanelMate configuration. Once you have downloaded a new configuration, this information will be updated to reflect the new configuration information.

## Enter Run Mode

Run Mode allows you to display the configuration downloaded to the PanelMate unit and communicate to the PLC (or Host) of your choice. If a new configuration has not been downloaded, the unit will display the demonstration configuration. For more information on Run Mode, refer to your PanelMate Getting Started Manual.

## Calibrate Touchscreen

Touchscreen units have a calibration routine that must be performed to determine the boundaries of the video on your touchscreen. Refer to Touchscreen Information for instructions on calibrating the touchscreen.

# TouchPanel Information

## PanelMate Operation

The most basic job of a PanelMate unit is to replace the functions of traditional hard-wired operator station devices such as pushbuttons, lamps and message displays. To replace each category of hard-wired devices, the PanelMate unit supplies a specific visual tool or "template" which can be arranged onscreen with other templates.

During operation, you can select a template to "arm" control buttons or numeric entry. To select a template, touch the TouchPanel area with your finger. Moving your finger around the TouchPanel will cause templates to become outlined or "selected". As you move your finger you will see a correlation between the position of your finger on the TouchPanel and the position of the templates of the screen.

Once a template has been selected or "armed", you can press any desired control button to take action.

For more information on PanelMate online operation, refer to your PanelMate Getting Started User's Guide or Online Operation User's Guide.



## CAUTION

**Never use foreign objects (pens, screwdrivers or similar) to activate the TouchPanel, numeric keypad or control buttons. Foreign objects may damage the membrane surfaces, causing unreliable operation or failure.**

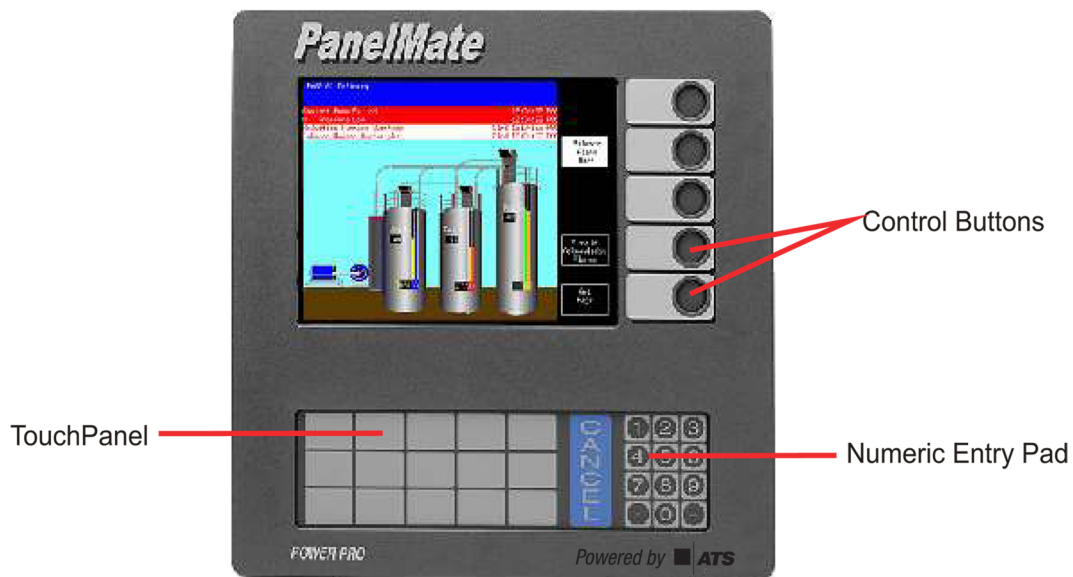

Representative PanelMate TouchPanel Unit

# Touchscreen Information

## PanelMate Operation

The most basic job of a PanelMate unit is to replace the functions of hard-wired operator station devices such as pushbuttons, lamps and message displays. To replace these devices, the PanelMate unit supplies a "template".

During operation, you can select a template to "arm" control buttons or numeric entry. Once a template has been selected or "armed", you can press any desired control button to take action.

The touchscreen is designed for finger or gloved operation only, and does not require the same actuation force as a mechanical switch. A light touch will produce the same result as a heavy one.

For more information refer to your PanelMate Online Operation User's Guide.



Pressing directly on the display will activate a template.

## Touchscreen Cleaning

A Cleaning Mode utility is provided to make touchscreen cleaning safe and easy. To access it:

- 1) Place the PanelMate unit in Run Mode
- 2) Select the Get Page control button
- 3) Select the More control button
- 4) Select the Setup Page control button
- 5) Select the Cleaning Mode template
- 6) Press the Execute control button

After pressing the Execute button, the Cleaning Mode screen will appear. While this screen is displayed, the touchscreen will not respond to your random touch. After you have finished cleaning the touchscreen, you must return to normal operation by pressing the screen's numbered corners in sequential order: 1,2,3,4.

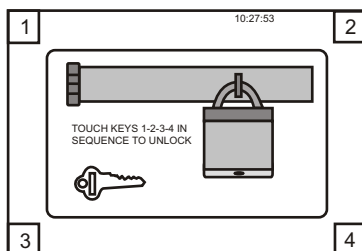

## Touchscreen Calibration

You can calibrate your unit's touchscreen in both Offline and Run modes. To access the calibration screen when in Offline mode, select the Calibrate Touchscreen template on the Offline Mode Menu. To access the calibration in Run mode:

- 1) Select the Get Page control button from the default control buttons
- 2) Select the More control button
- 3) Select the Setup Page control button
- 4) Select the Calibrate Touchscreen template
- 5) Press the Execute control button

Although the Offline and Run mode calibration screens are slightly different in appearance, they both use the same calibration process. To calibrate, press the eight boxes/crosshairs located around the screen edges. You may press them in any order, but all must be pressed to calibrate.

Each box/crosshair will turn green when pressed. After the first pass, the boxes/crosshairs will change color to indicate the screen is ready for the second pass. Again, press all eight boxes/crosshairs around the screen edge. When you have pressed the last, the unit will return to normal operation.

Press these boxes/crosshairs twice

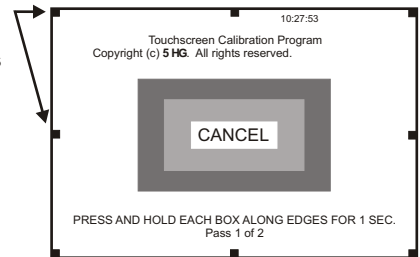

## CAUTION

**Never use foreign objects (pens, screwdrivers or similiar) to activate the Touchscreen. Foreign objects may damage the membrane surfaces, causing unreliable operation or failure.**

**Do not use solvents or other harsh cleaning compounds on the touchscreen. Solvents and abrasive cleaning compounds will cause permanent damage to the touchscreen.**

# PanelMate Power Pro 5000 TouchPanel Cutout Template



## CAUTION

Care should be taken when tightening the nuts. The fasteners must be tightened enough to obtain a proper seal, but not over tightened to the point where the threads are stripped or the gasket is rendered useless. Always use a torque wrench when installing your PanelMate unit.

**Torque Limits for Studs**  
**20 inch-pounds for #10-32 nuts**

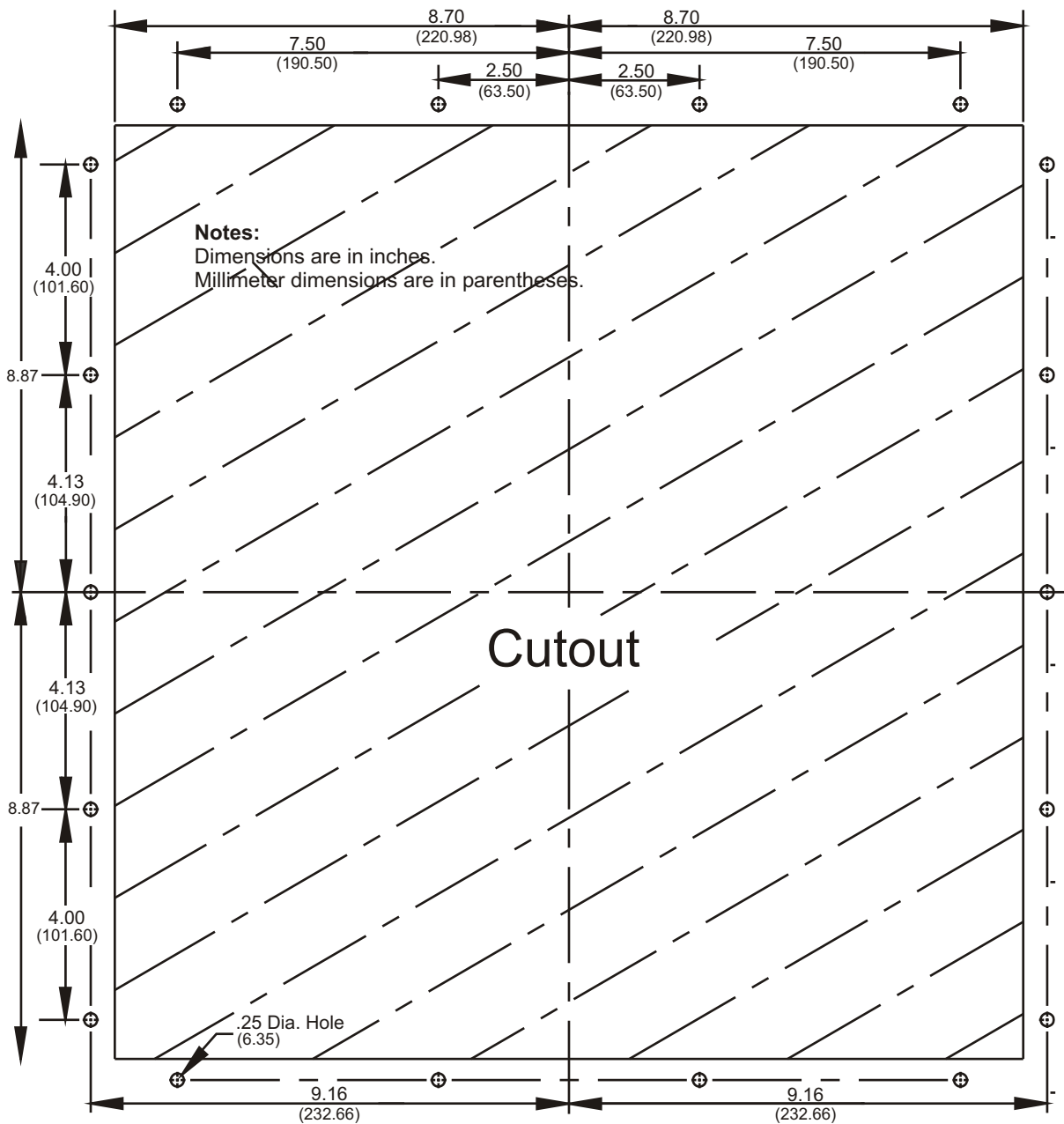

# PanelMate Power Pro 5000 Split Cutout Template



## CAUTION

Care should be taken when tightening the nuts. The fasteners must be tightened enough to obtain a proper seal, but not over tightened to the point where the threads are stripped or the gasket is rendered useless. Always use a torque wrench when installing your PanelMate unit.

**Torque Limits for Studs**  
**17 inch-pounds for #10-32 nuts**  
**7 inch-pounds for #8-32 nuts**

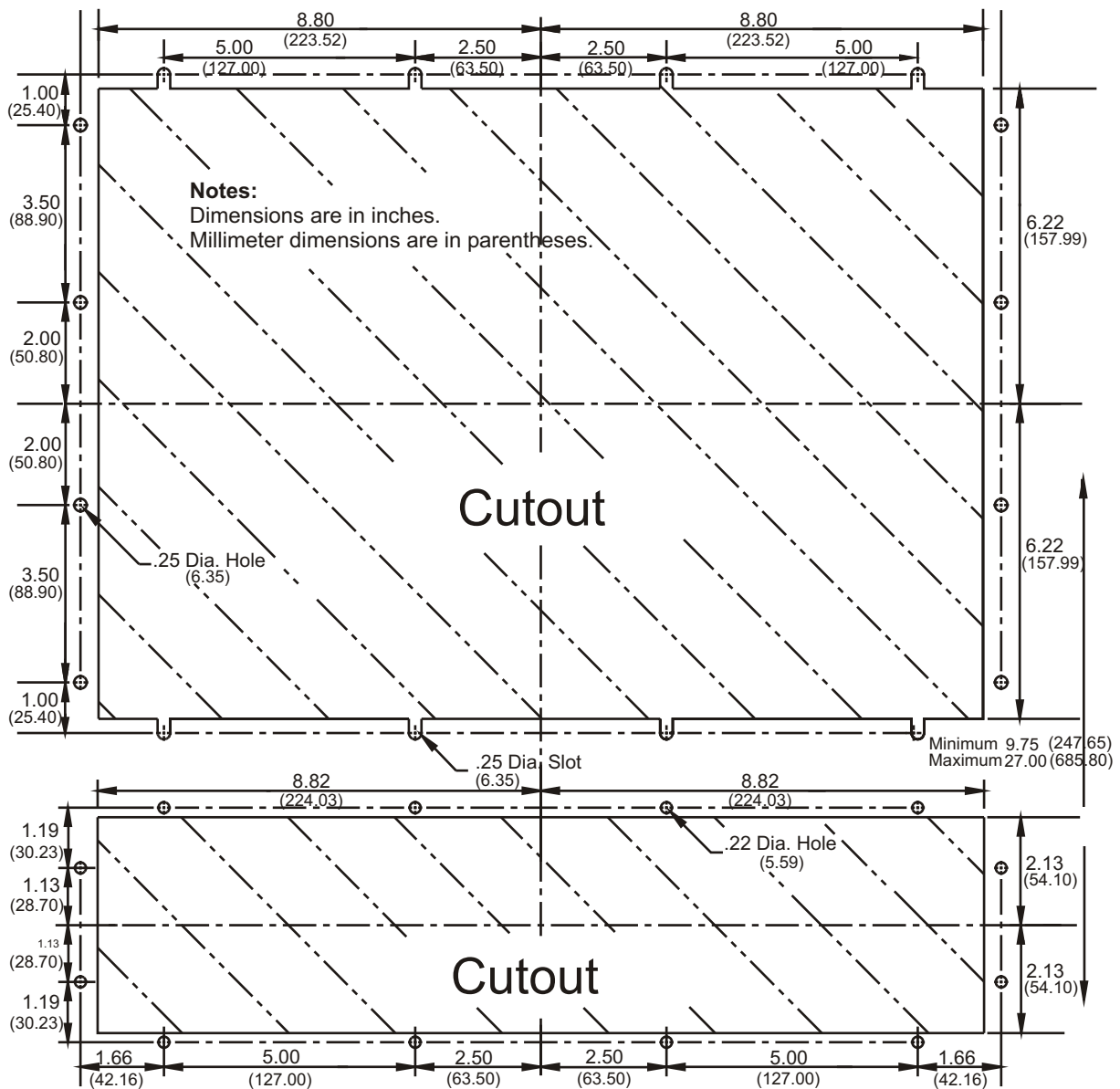

# PanelMate Power Pro 5000 Touchscreen Cutout Template



## CAUTION

Care should be taken when tightening the nuts. The fasteners must be tightened enough to obtain a proper seal, but not over tightened to the point where the threads are stripped or the gasket is rendered useless. Always use a torque wrench when installing your PanelMate unit.

**Torque Limits for Studs**  
**10 inch-pounds for #10-32 nuts**

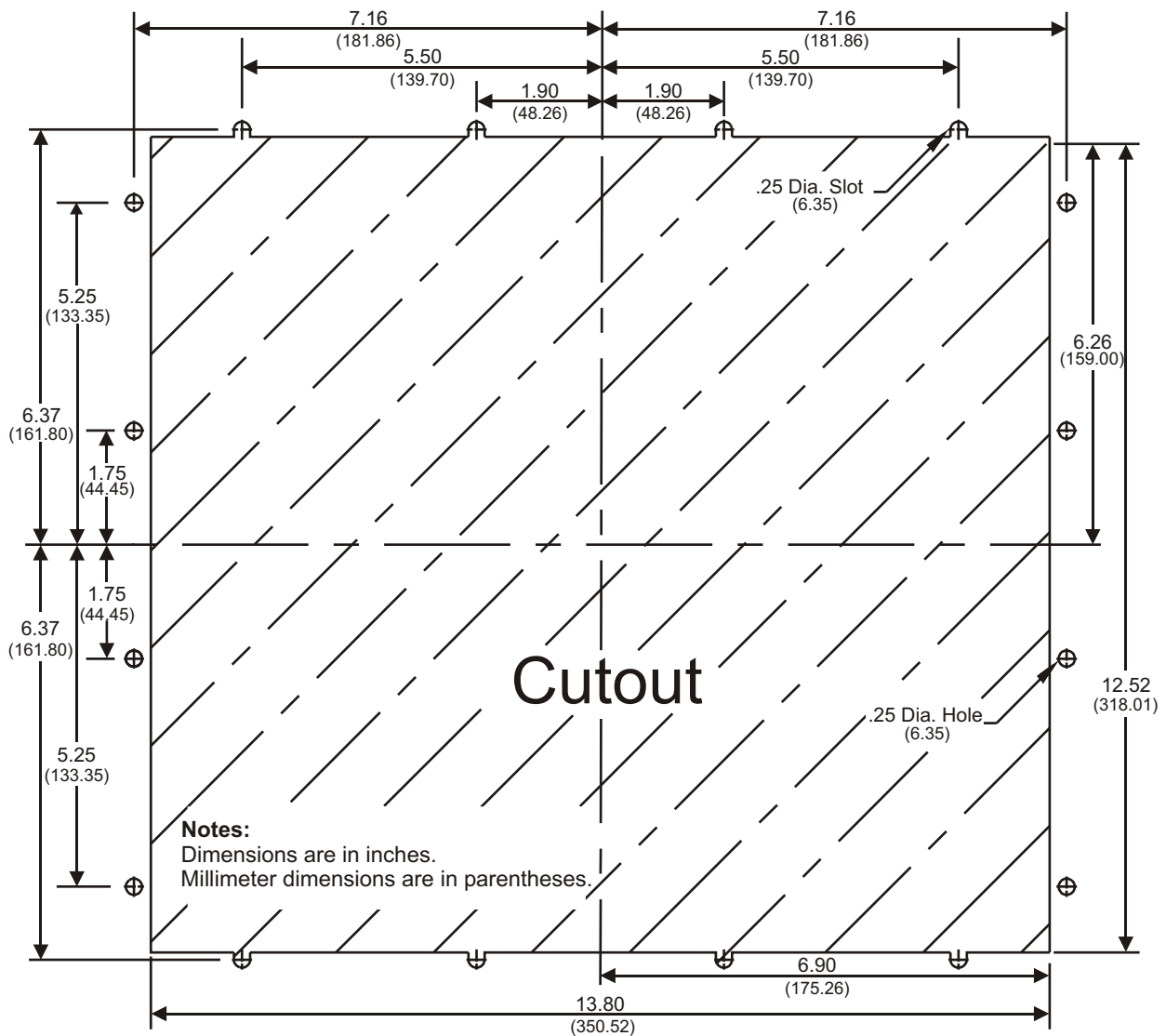

# Specifications

## Temperature

- Operating: 0-50° C
- Non-operating: -20-70° C

## Humidity (non-condensing)

- Operating: 20%-95%
- Non-operating: 20%-95%

## Installation Rating

Approved for use in Type 4, 4X and 12 installations when properly mounted in a correspondingly rated enclosure

## Vibration

- Operating: 1g at 10-500 Hz
- Non-operating: 1g at 10-500 Hz

## Shock

- Operating: 30g
- Non-operating: 30g

## Pollution

Pollution Degree 1 - Rated for exposure to dry or non-conductive pollutants only

## Altitude

- Operating: 10,000 ft (3048 m) above sea level
- Non-operating: 40,000 ft (12,192 m) above sea level

## ESD Immunity

- Air: IEC 1000-4-2, Level 4 (+/- 15kV)
- Contact: IEC 1000-4-2, Level 4 (+/- 8kV)

## Radiated Immunity

IEC 1000-4-3 (10V/m) 27mHz to 1GHz 80% AM modulation

## Conducted Immunity

IEC 1000-4-6 10V from 150kHz to 80mHz, 80% AM modulation with 1kHz sine wave

## Surge Immunity

IEC 1000-4-5 500V

## Radiated/Conductive

CISPR 22, Class A Emission

## Electrical Fast Transient

IEC 1000-4-4, Level 3 (2kV) on power lines (1kV) on I/O lines

P/N 01-00505-00

## Line Frequency Magnetic Field Immunity

IEC 1000-4-8 Level 3, 30A/m at 50Hz and 60Hz

## Voltage

AC Models

- 120/230VAC, -15%/ +10%

DC Models

- 24VDC, -15%/ +20%

## Power

AC Models

- 33 Watts (without high speed interface installed)
- 40 Watts (with high speed interface installed)

DC Models

- 24 Watts (without high speed interface installed)
- 30 Watts (with high speed interface installed)

## Current

AC Models

- 0.40/0.20A (without high speed interface installed)
- 0.50/0.25A (with high speed interface installed)

DC Models

- 1.2A (without high speed interface installed)
- 1.5A (with high speed interface installed)

## Peak Inrush Current

AC Models

- 14A

DC Models

- 9A

## Serial Port Rate

Selectable; 110 to 38,400 baud

## Serial Port 1 Configuration

DB9S connection selectable for RS232, RS422, or RS485-2 signal levels

## Serial Port 2 Configuration

DB9S connection selectable for RS232, RS422, or RS485-2 signal levels

## TouchPanel Weight

- 24 Lbs (without high speed interface installed)
- 25 Lbs (with high speed interface installed)

## Touchscreen Weight

- 17 Lbs (without high speed interface installed)
- 18 Lbs (with high speed interface installed)

At ATS, our Legacy Products Division continues to support factories worldwide through partnerships with industry leading OEM's. This PanelMate product is our latest acquisition. It continues our tradition of assisting customers like you by allowing for capital investment decisions to be made within your timeframe. Through our support of end-of-life components, existing production lines stay running without the need for expensive upgrades.

ATS didn't earn its reputation for making factories run better by accident. We earned it by proving ourselves in some of the most advanced and demanding factories in the world. Our breadth of expertise stretches much farther than Legacy Products. With our award winning Industrial Parts Services we offer some of the world's top companies high quality repairs that look and perform like new. We also provide customers a variety of on-site Industrial Parts Services including Repair Parts Management, Reliability Engineering, Power Tool / Asset Management and Calibration Services. No one offers greater expertise in Repair Parts Services than ATS.

ATS' state-of-the-art repair centers are ISO 9001 registered assessed by the British Standards Institute (BSI). Our calibration labs are ISO 17025 accredited assessed by A2LA with standards traceable to the National Institute of Standards and Technology.

## **Avanced Technology Services**

8201 N University

Peoria, IL 61615

**1.800.328.7287**

[www.buypanelmate.com](http://www.buypanelmate.com)